

# **Williamson Pro Series Pyrometer**

## **Installation and Operation Manual**

**Revision 04**



**This product meets EMC Directive  
89/366/EEC and Low Voltage  
Directive 73/23/EEC and carries the  
CE Mark.**

## Introduction

### Country of Origin

Williamson products are manufactured, calibrated, serviced and repaired at the Concord, Massachusetts, USA corporate headquarters.

### Contact Information

#### General Inquiries:

**Williamson Corporation**  
**70 Domino Drive**  
**Concord, MA 01742, USA**  
[www.williamsonir.com](http://www.williamsonir.com)  
**Tel: +1-978-369-9607**  
**Fax: +1-978-369-5455**  
<https://www.williamsonir.com/contact-us/>

#### Service and Repair:

<https://www.williamsonir.com/request-technical-support/>

#### Warranty Service:

<https://www.williamsonir.com/request-technical-support/request-rma/>

### Corporate Statement

Founded in 1951, Williamson Corporation specializes in the manufacture of industrial infrared thermometers, commonly referred to as pyrometers, with a careful attention to wavelength selection for optimal performance and accuracy. Williamson offers six infrared technologies and three product tiers in order to satisfy the requirements of every industrial application.

Infrared Technologies	Short-Wavelength (SW), Long-Wavelength (LW), Specialty-Wavelength (SP), Two-Color (TC), Dual-Wavelength (DW), Multi-Wavelength (MW)
-----------------------	---

### Quality Statement

The Williamson calibration facility is ISO 9001:2015 certified. It is the policy of Williamson to provide our customers with products and services that meet their expectations and continuously improve our quality performance.

### Warranty

**New Sensor Warranty:** Williamson Corporation (“Williamson”) warrants solely to the end user (the “Customer”) of each new Williamson temperature-sensing product (the “Product”), that such Product will be free from defects in material or workmanship for a period of twenty-four (24) months from the date of shipment by Williamson to the Customer. In the event that the Product proves to be defective during such warranty period, Williamson will repair or replace the Product without charge or refund the amount paid for the Product, in accordance with these Warranty terms.

**Service Warranty:** Williamson Corporation (“Williamson”) warrants solely to the end user (the “Customer”) of each component repaired or replaced, that such will be free from defects in material or workmanship for a period of twelve (12) months from the date of shipment by Williamson to the Customer. In the event that the Product proves to be defective during such warranty period, Williamson will repair or replace the Product without charge or refund the amount paid for the Product, in accordance with these Warranty terms.

In order to make a warranty claim, the Customer must return the Product to Williamson with all freight charges prepaid. The repair or replacement work will be scheduled with the Customer and return shipped via a ground service or standard internationally recognized courier service. If the Customer requests a premium delivery service, the Customer will pay the difference between the standard and premium service. The determination of whether a Product is defective shall be made by

Williamson in its reasonable discretion. To report a warranty claim, the Customer shall contact a local Williamson representative or Williamson's office in Concord, Massachusetts, USA.

**Exclusions:** Williamson makes no warranty with respect to defective conditions or non-conformities resulting from any of the following: any modifications, misuse, neglect, accident or abuse; improper wiring, repairing, splicing, alteration, adjustment, installation, storage or maintenance performed in a manner not in accordance with Williamson's or its vendor's specifications or operating instructions; failure of any Customer to apply Williamson's previously applicable modifications or corrections; or items not manufactured by Williamson or purchased by Williamson pursuant to its procurement specifications. Williamson makes no warranty with respect to products which have had their serial numbers or intellectual property notices removed or altered. Defects occurring as a result of improper packaging of a Product for return to Williamson for repair or otherwise will not be covered under this warranty.

**Remedies:** Williamson's sole liability and Customer's exclusive remedy under this limited warranty shall be, at Williamson's election to (a) correct any failure to conform to the above warranties, (b) replace the non-conforming Product or (c) to refund or provide a credit in the amount of the purchase price paid by the Customer to Williamson or its authorized reseller for the Product. The above remedies are available only if the defect occurs and Williamson is notified promptly in writing within the applicable warranty period and Williamson confirms that such non-conformity exists.

**Limitations:** EXCEPT AS EXPRESSLY PROVIDED IN THIS WARRANTY, THE PRODUCTS ARE PROVIDED "AS IS" WITHOUT WARRANTY OF ANY KIND AND WILLIAMSON HEREBY DISCLAIMS ALL WARRANTIES, WHETHER EXPRESS OR IMPLIED, ORAL OR WRITTEN, WITH RESPECT TO THE PRODUCTS AND ANY SERVICES INCLUDING, WITHOUT LIMITATION, ALL IMPLIED WARRANTIES OF MERCHANTABILITY OR FITNESS FOR ANY PARTICULAR PURPOSE AND NON-INFRINGEMENT.

Williamson's liability for damages to any Customer for any cause whatsoever, regardless of the form of any claim or action relating to the use of a Product, shall not exceed the aggregate amount paid by such Customer for such Product. In no event shall either party be liable for any loss of data, profits or use of the Products, or for any special, incidental, indirect or consequential damages arising out of or in connection with the use or performance of any Products. The limitations set forth in this warranty shall not serve to limit Williamson's recovery in matters involving Customer's misappropriation of Williamson's intellectual property.

In no event shall Williamson, its directors, officers, employees, agents or affiliates, be liable for any indirect, incidental, special, exemplary, multiple, punitive or consequential damages (or any costs relating to the foregoing), including lost profits or loss of data or use of the Products, whether based on contract, tort (including negligence), strict liability or other legal theory, even if Williamson, or any of its directors, officers, employees, agents or affiliates has been advised of the possibility of such damages. Except as set forth in this warranty, in no event shall Williamson be liable to Customer, or other third parties for any damages whatsoever.

## Safety Warning Statements



**Warning**

No user-serviceable parts inside. Do not open.



**Warning**

Only *trained and qualified personnel* are allowed to install, replace or service this equipment without risk of voiding the warranty.



**Warning**

Use of the equipment in a manner not specified by Williamson may result in protection impairment.



**Warning**

Installation of the equipment must comply with local and national electrical codes.



**Warning**

Interface Modul connected to Pyrometer: Power rating: 100-240VAC @ 0.125A

Standalone Pyrometer: 24VDC @ 0.3A

These products rely on the building's installation for short-circuit (overcurrent) protection.

The Interface Module must be disconnected from the power source by removing the power cable.



**Warning**

Ultimate disposal of this product should be handled according to all national laws and regulations.

## **EMC Statements**

### **Class A notice of FCC**

This equipment has been tested and found to comply with the limits for a Class A digital device, pursuant to Part 15 of the FCC Rules. These limits are designed to provide reasonable protection against harmful interference when the equipment is operated in a commercial environment. This equipment generates, uses and can radiate radio frequency energy and if not installed and used in accordance with the instruction manual, may cause harmful interference to radio communications. Operation of this equipment in a residential area is likely to cause harmful interference in which case users will be required to correct the interferences at their own expense.

### **Class A Notice for Canada**

This Class A digital apparatus complies with Canadian CES-003.

Cet appareil numérique de la classe A est conforme à la norme NMB-003 du Canada

### **EMC Environmental Conditions for Products Installed in the European Union**

This section applies to products to be installed in the European Economic Union

The equipment is intended to operate under the following environmental conditions with respect to EMC

- A separate, defined location this is under the user's control.
- As a minimum, earthing and bonding shall meet the requirements of ETS 300 253 1995 or CCITT K27 1996.
- AC Power distribution inside the building shall be, as a minimum, one of the following types as defined in IEC 6064-3: 1993
  - o TN-S
  - o TN-C
  - o TT
  - o IT

In addition, if equipment is operated in a domestic environment, radio-frequency interference may occur.

### **CB Scheme**

Certified to CB Scheme IEC 60950-1. Second Edition.



### **Laser Safety Statement**

This product contains a laser aimer:

### **Laser Radiation**

**Do not Stare into the Beam. Class 2 Laser Product**

**0.9mW Max Output 510-530nm**

This device has been tested in accordance with and complies with IEC60825 2014 and 21 CFR 1040,10 and 1040, 11.

# Contents

<b>1.0</b>	<b>PRODUCT OVERVIEW .....</b>	<b>8</b>
1.1	Williamson Technology – Where Wavelength Matters.....	8
1.2	Pro Series Pyrometers.....	9
1.3	Aiming and Optical Configuration.....	9
1.4	Product Specifications .....	11
1.5	Pyrometer Installation Checklist.....	12
<b>2.0</b>	<b>MECHANICAL INSTALLATION.....</b>	<b>13</b>
2.1	Traditional Style Pyrometer.....	13
2.2	Fiber Optic Style Pyrometer.....	14
2.3	Water Cooling and Air Purge Accessories.....	15
2.3.1	Cooling Specifications .....	15
2.3.2	Water Cooling (WC) and Air Purge (AP).....	15
2.3.3	Protective Cooling Jacket (PCJ) .....	16
2.4	Mounting Accessories.....	18
2.4.1	Traditional Style Swivel Bracket (SB) .....	18
2.4.2	Fiber Optic Swivel Bracket (FOSB) .....	18
2.4.3	Fiber Optic Sight Tube Swivel Bracket (STSB) .....	19
2.5	Flange Mounts for Traditional and Fiber Optic Style Pyrometers.....	19
2.6	Explosion (EXP) Proof Configuration.....	21
2.7	Interface Module (IM) .....	22
<b>3.0</b>	<b>ELECTRICAL INSTALLATION.....</b>	<b>23</b>
3.1	Analog and Digital Configurations .....	23
3.2	Electrical Wiring.....	23
3.3	Jumper Positions.....	24
3.4	Explosion-Proof Electrical Wiring.....	24
3.5	Interface Module Electrical Hook Up Connections.....	25
3.6	Alarm Function Wiring.....	26
<b>4.0</b>	<b>NAVIGATING THE PYROMETER MENU.....</b>	<b>27</b>
4.1	Display Mode .....	27
4.2	Set Up Mode – Main Menu.....	27
4.3	Set Up Mode, Submenu Level.....	27
4.3.1	Signal Conditioning Submenu Group.....	28
4.3.2	Configure I/O Submenu Group .....	29
4.3.3	Configure Alarms Submenu Group .....	30

4.3.4	Configure ESP Submenu Group* Only for Models TC, DW, MW .....	31
4.3.5	Diagnostics Submenu Group.....	31
4.3.6	System Specification Submenu Group.....	32
4.3.7	Configure Network Submenu Group .....	32
<b>5.0</b>	<b>TROUBLESHOOTING .....</b>	<b>33</b>
5.1	Common Troubleshooting Errors .....	33
5.2	Technical Notes.....	33
5.3	Maintenance.....	34

# 1.0 PRODUCT OVERVIEW

## 1.1 WILLIAMSON TECHNOLOGY – WHERE WAVELENGTH MATTERS

Infrared pyrometers are non-contact optical devices that calculate a temperature value based on measured infrared energy. The amount of energy collected by a sensor is influenced by the emissivity characteristics of the target and the transmission characteristics of any intervening optical obstructions between the sensor and the measured target. With thoughtful wavelength selection, Williamson can dramatically reduce or even eliminate application errors due to optical obstructions, emissivity variation, background reflections, and misalignment.

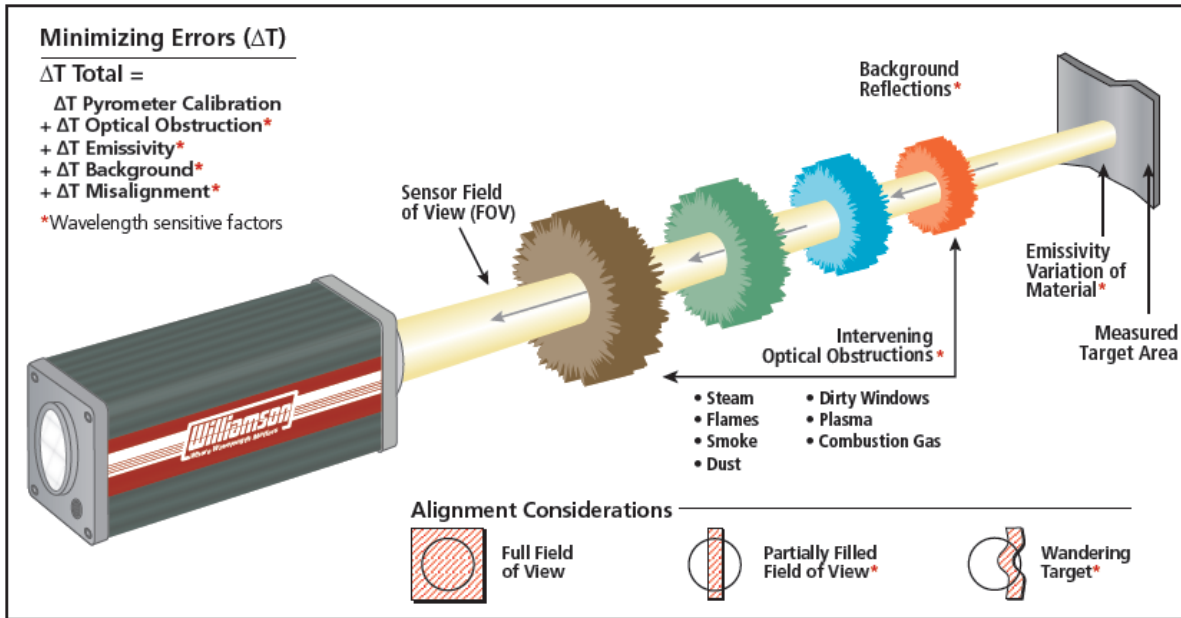

Williamson offers 6 different infrared technologies with a variety of wavelength options, multiple optical configurations, temperature spans and accessories to ensure that each pyrometer is optimally designed for each application. To ensure the most accurate measurement, select the pyrometer technology and wavelength that best compensates for the application conditions. Visit [www.williamsonir.com](http://www.williamsonir.com) for guidance

Single-Wavelength		
Short-Wavelength (SW)	Long-Wavelength (LW)	Specialty-Wavelength (SP)
Errors are relatively small for moderate emissivity variation, optical obstruction and misalignment, particularly at lower temperatures. Certain models can view through common interferences.	Low-cost pyrometers ideal for general purpose applications measuring temperatures below 100°C / 200°F.	Used when the target is least reflective and most opaque at a specific wavelength or when optical obstructions are most transparent at a specific wavelength.

Ratio and Multi-Wavelength		
Two-Color (TC)	Dual-Wavelength (DW)	Multi-Wavelength (MW)
Ratio Pyrometers designed to compensate for emissivity variation and modest optical obstruction or misalignment.	Ratio Pyrometers designed to measure the hottest temperature viewed. Select wavelength sets tolerate water, steam, flames, plasma, and laser energy. More tolerant of scale, misalignment, and optical obstructions than Two-Color.	Used for non-greybody materials such as aluminum, copper, stainless steel, and zinc. Application specific algorithms adjust for complex emissivity characteristics.



## 1.2 PRO SERIES PYROMETERS

The Pro Series pyrometers are available in traditional and fiber optic styles. The traditional style includes visual aiming with a laser aiming option, and the fiber optic style includes an aim light option. The pyrometers can be configured to operate as a stand-alone transmitter or with the optional remote interface module.



It is possible to view measured parameters and edit menu settings via the local pyrometer interface or the remote interface module.



## 1.3 AIMING AND OPTICAL CONFIGURATION

Williamson pyrometers calculate the temperature of a target based on the energy that is measured in the field of view. As the figure below illustrates, the focal distance and optical resolution are used to establish the size of the field-of-view at various distances. All Williamson pyrometers are fixed focus. This means that they can be used at any distance but the optical resolution and focal distance are set at the time of manufacture.

## Field of View

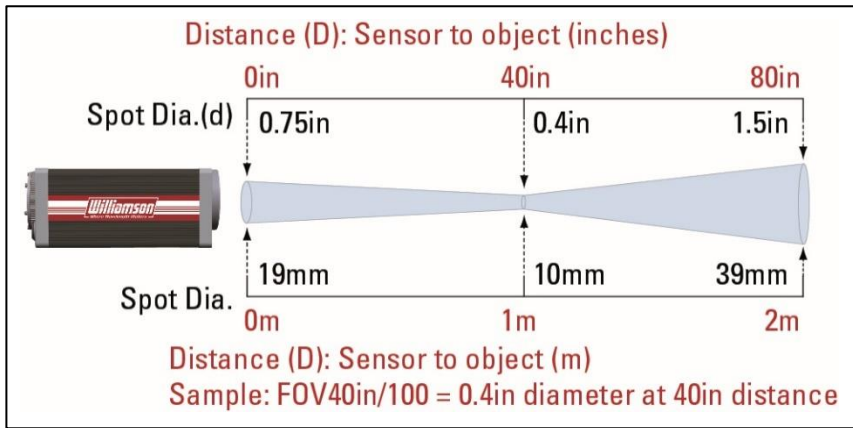

### Lens Diameter by Pyrometer Type

#### Fiber-Optic

0.5 inches

#### Traditional

0.75 inches\*

#### Auto Null

1.5 inches\*

\*0.5" if calibrated above 2600 F.

## Determining the Field of View Diameter

D = focal distance  
 F = optical resolution  
 L = lens diameter  
 x = working distance  
 d = viewing diameter

For  $0 < x < D$

$$d = L + \left(\frac{x}{D}\right) \left[\left(\frac{D}{F}\right) - L\right]$$

For  $x > D$

$$d = \left[\frac{x - x_1}{D - x_1}\right] \left(\frac{D}{F}\right)$$

Where  $x_1 = \frac{(L)(D)}{\left[\left(\frac{D}{F}\right) + L\right]}$

For  $x = D$

$$d = D/F$$

## Edge Effect and Focal Plane with Ratio Pyrometers (Two-Color or Dual-Wavelength)

For most applications, the measured target fills the pyrometer's field of view, but with some applications involving a small or moving target, it is possible to have a partially filled viewing area. For these applications, it is possible to use a ratio pyrometer (Two-Color or Dual-Wavelength). To avoid edge effect issues that can occur with partially-viewed targets or any significant optical obstruction, it is important that the measured target is within the focal plane of the pyrometer. This is the depth of field for which the object appears to be crisply focused when viewed by the pyrometer. See [www.williamsonir.com](http://www.williamsonir.com) for more information.

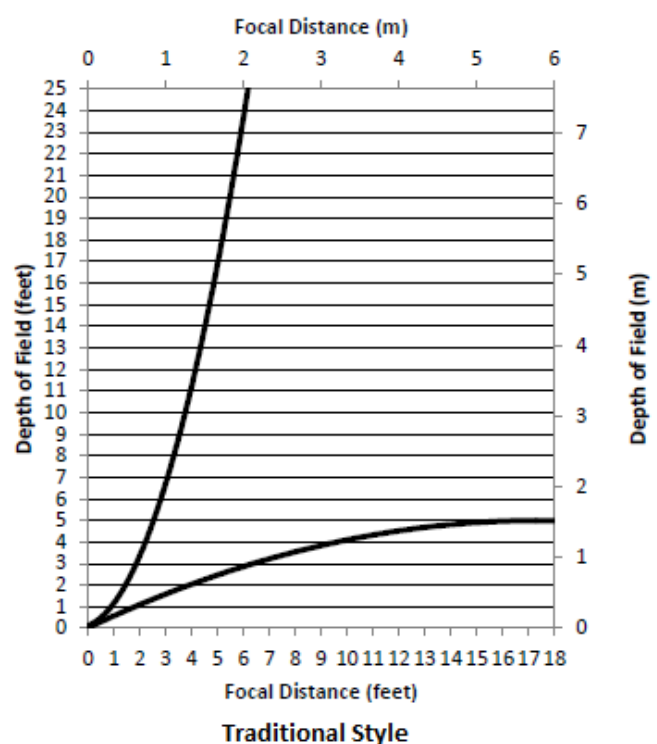
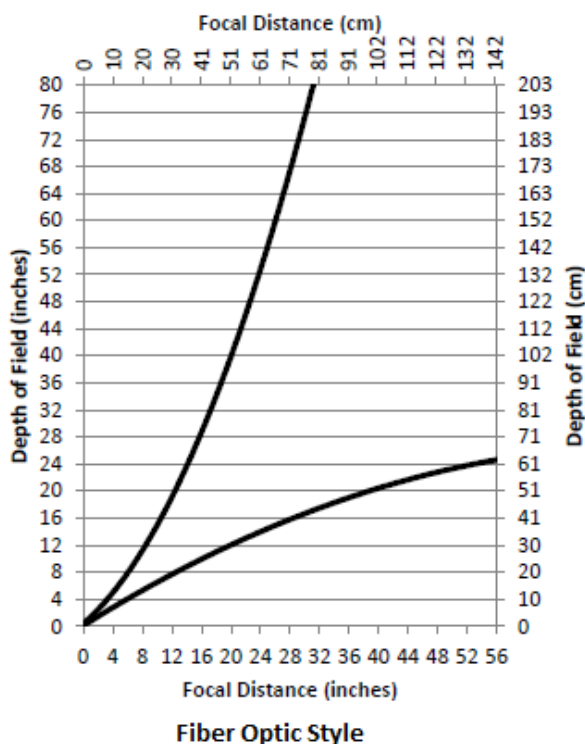

## 1.4 PRODUCT SPECIFICATIONS

Pro Series Specifications	
<b>Temperature Limits</b>	0 to 5500°F / 0 to 3040°C (actual ranges vary by model) – See datasheet for specific temperature ranges
<b>Spectral Response</b>	<b>SW:</b> Varies by model <b>SP:</b> Varies by model <b>LW:</b> 8-12 um, General Purpose waveband <b>TC:</b> Fixed wavelength-set at around 1µm <b>DW:</b> Range of precisely selected narrow wavelength bands <b>MW:</b> Range of precisely selected narrow wavelength bands
<b>Optical Resolution</b>	Range of optics selectable by model
<b>Accuracy</b>	<b>LW, SP:</b> 0.50% of Reading or 2°C whichever is greater <b>SW, TC, DW, MW:</b> 0.25% of Reading or 2°C whichever is greater
<b>Repeatability</b>	Better than 1°C
<b>Emissivity (SW, LW, SP)</b>	0.010 to 1.500
<b>E-Slope (TC, DW, MW)</b>	0.000 to 2.000 (E-Slope offset -1.000 to +1.000)
<b>Response and Update Time</b>	<b>SW*, LW, SP*, TC :</b> 10ms initial response with 5ms update time <b>DW, MW :</b> 50ms initial response with 25ms update time *Auto Null models: 100ms initial response with 50ms update time
<b>Analog Outputs</b>	0/4-20mA output (max impedance 1000 ohms)
<b>Alarms</b>	One field-selectable N.O. or N.C. Relay rated 1A @24V
<b>Analog Input</b>	4-20mA/0-20mA input (impedance 250 ohms)
<b>Digital Communications</b>	Bi-Directional RS485 and RS232 Multidrop communications available
<b>Human Interface</b>	Built-in Menu System with Averaging, Peak/Valley Hold (Time or Temp Reset), Programmable Outputs & Alarms, and ESP Filters ( <b>TC, DW, MW</b> only)
<b>Measured Parameters</b>	<b>All:</b> Filtered and Unfiltered Temperature, Ambient Temperature, Rate of Change <b>TC, DW, MW:</b> Signal Strength (Emissivity), Signal Dilution <b>Auto Null:</b> Cell Strength
<b>Input Power</b>	24Vdc (300mA) max
<b>Ambient Temperature Limits</b>	0 to 150°F / -17 to 65°C with Water Cooling Plate: 350°F/175°C (varies with water rate & temp) with Protective Cooling Jacket: 600°F/315°C Fiber Optic Cable & Lens Barrel: 400°F / 200°C
<b>Enclosure Rating</b>	Corrosion Resistant Enclosure designed to NEMA4X (IP65). Optional NEMA 7, IECEx, and ATEX enclosures are available for hazardous environments
<b>Operating Altitude</b>	2000 Meters
<b>Pollution Degree</b>	Interface Module: 3 Standalone Pyrometer: 4
<b>Weight</b>	Sensor: 3.6lbs (1.6kg)
<b>Dimensions</b>	Sensor: 3.5in x 3.5in x 8.25in / 89mm x 89mm x 210mm
<b>Certification</b>	NIST: Calibration certification is standard with each sensor CE: EMI/ RFI for heavy industry; LVD ( Low Voltage Directive)

Warranty	2 years
----------	---------

All

Williamson pyrometers are precisely calibrated to NIST standards in accordance with Williamson procedures and ISO/IEC 17025:2005.

## 1.5 PYROMETER INSTALLATION CHECKLIST

In many cases, the pyrometer is “aim and shoot” right out of the box; however, the Williamson Pro Series pyrometers are versatile enough to adapt to the most challenging application conditions.

**Step 1:** Mechanically install the pyrometer.

**Step 2:** Provide the appropriate utilities, including power and air or water as required

**Step 3:** Configure the Input, Output and Alarm parameter settings as desired.

**Step 4:** Use the Diagnostics submenu to confirm wiring and data acquisition interface.

**Step 5:** Align the pyrometer.

**Step 6:** Adjust or confirm the appropriate emissivity compensation setting:

- Single-Wavelength Models (SW, LW, SP): Emissivity parameter setting
- Ratio Models (TC, DW): E-Slope Offset parameter setting.
- Multi-Wavelength Models (MW, MWF): Application Algorithm, E-Slope Offset parameter settings.

**Step 7:** Identify potential interference sources (hot reflected images, optical interference, and misalignment), adjust signal conditioning parameters as appropriate and confirm reliable pyrometer operation. Contact Williamson if professional assistance is desired.

## 2.0 MECHANICAL INSTALLATION

### 2.1 TRADITIONAL STYLE PYROMETER

LEGEND: INCHES [MILLIMETERS]

#### Side View

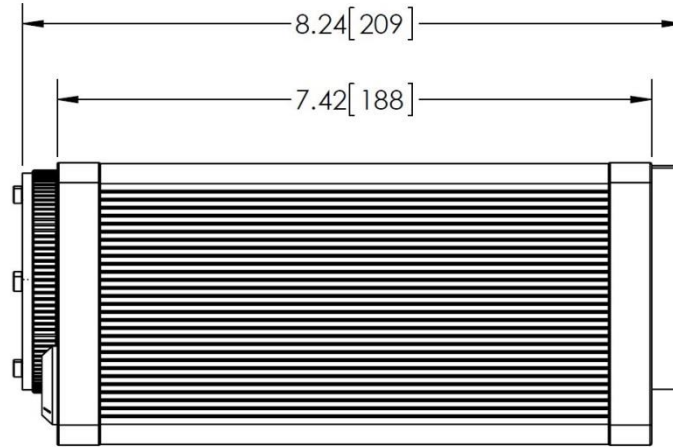

#### Bottom View

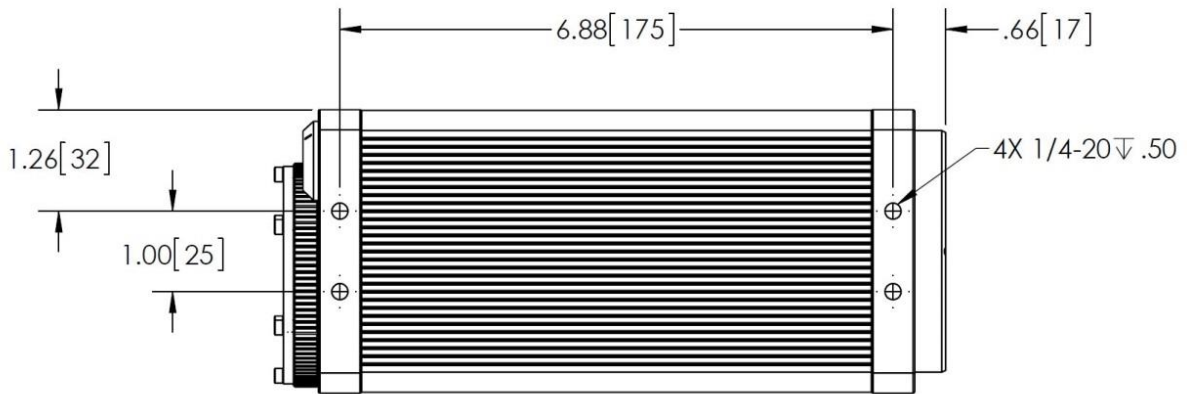

#### Front and Rear View

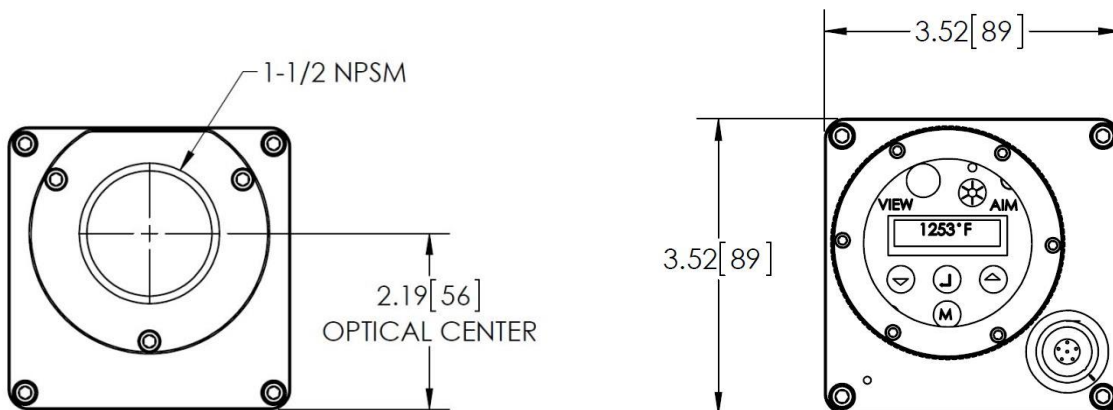

## 2.2 FIBER OPTIC STYLE PYROMETER

LEGEND: INCHES [MILLIMETERS]

### Side View

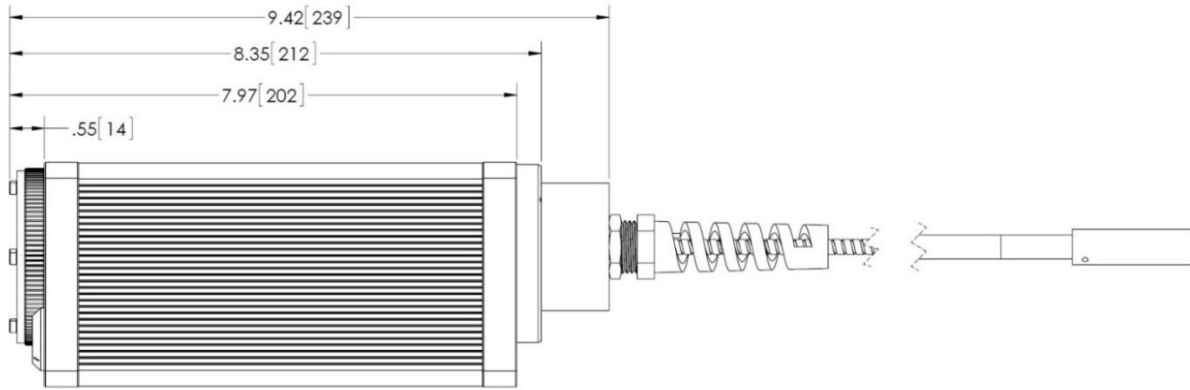

### Bottom View

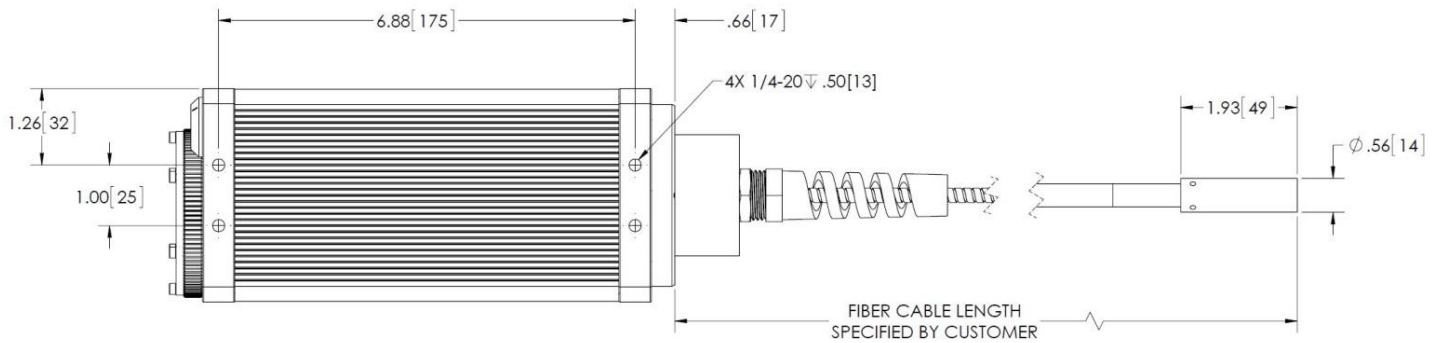

### Front and Rear View

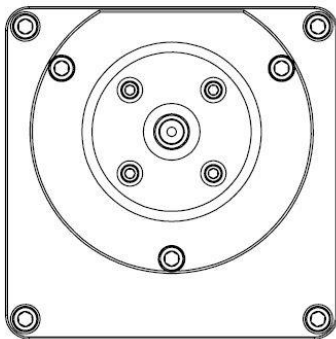

(WITH CABLE REMOVED)

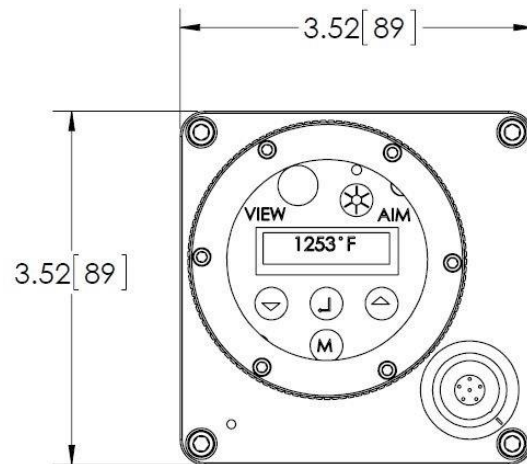

## 2.3 WATER COOLING AND AIR PURGE ACCESSORIES

### 2.3.1 Cooling Specifications

To protect the pyrometer electronics from high ambient operating temperatures, Williamson offers:

- A water-cooling plate (WC) which is typically used with ambient temperatures up to 200°F /95°C.
- A Protective Cooling Jacket (PCJ) which can be used with ambient temperatures as high as 600°F/315°C.

The actual cooling results vary with the water temperature and rate. See the table below for more details.

Ambient Temp	Water Flow Rate (assumes 68°F water temp)	
	PCJ	WC
200°F / 93°C	0.15 Gal / min 0.57 L / min	0.30 Gal / min 1.1 L / min
250°F / 121°C	0.30 Gal / min 1.1 L / min	---
300°F / 149°C	0.50 Gal / min 1.9 L / min	---
450°F / 232°C	0.75 Gal / min 2.9 L / min	---
600°F / 315°C	1.0 Gal / min 3.8 L / min	---

### 2.3.2 Water Cooling (WC) and Air Purge (AP)

LEGEND: INCHES [MILLIMETERS]

The water cooling plate can be used with both the traditional and fiber optic style pyrometers

#### Side View

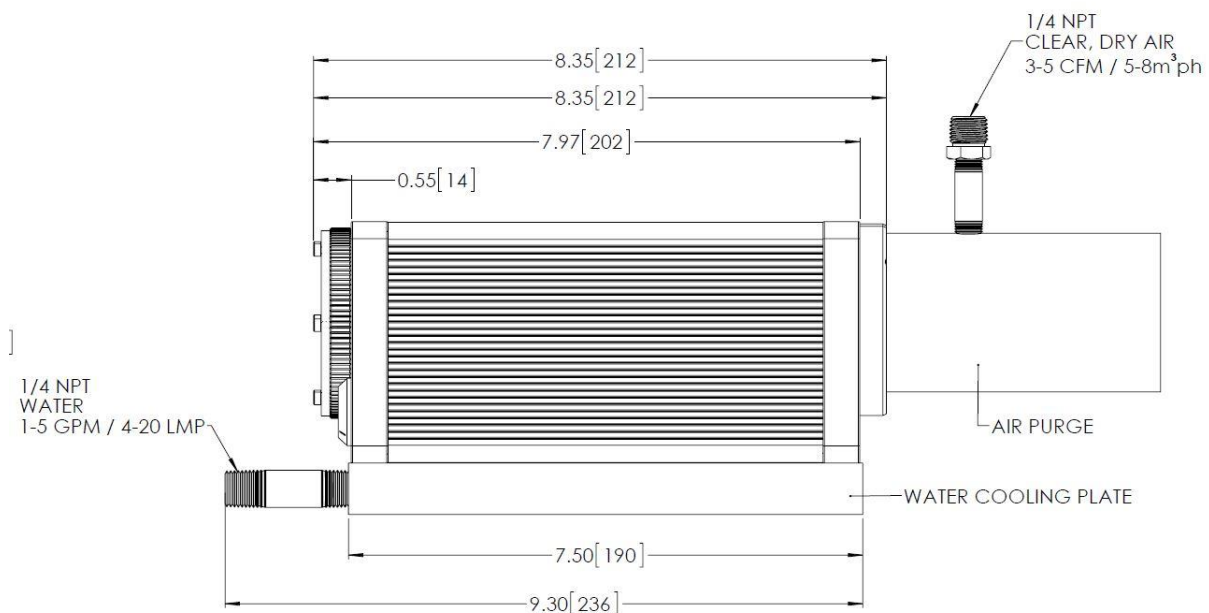

### Bottom View

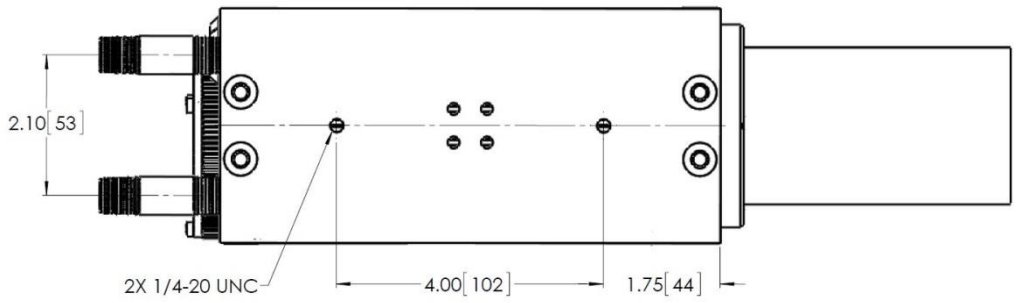

### Front and Rear View

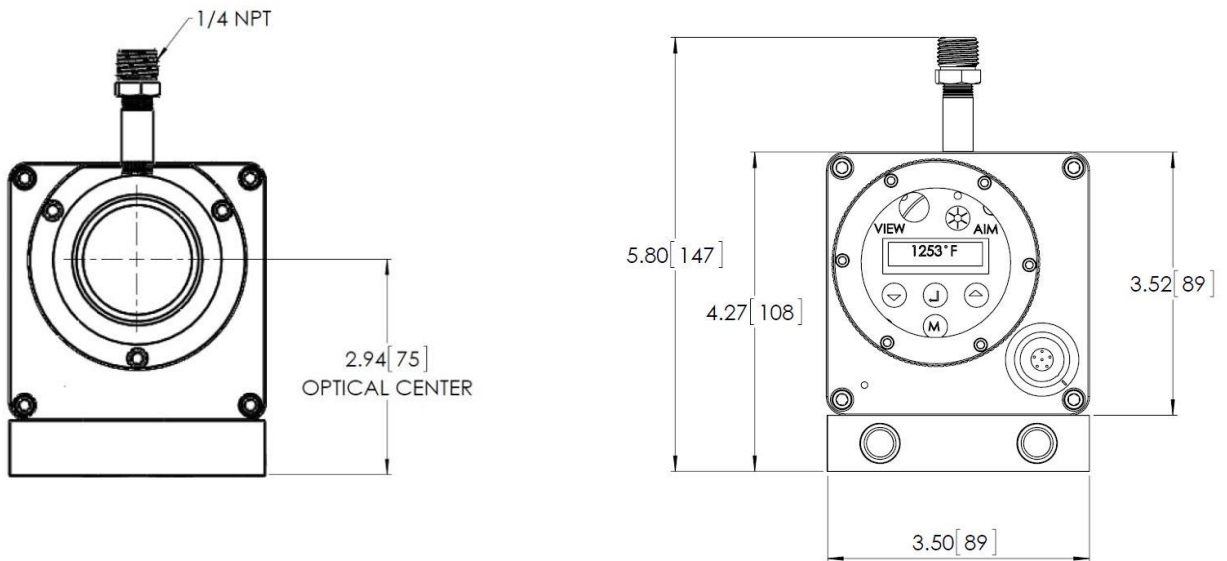

### 2.3.3 Protective Cooling Jacket (PCJ)

The protective cooling jacket can only be used with the traditional style pyrometers. For first time installation, unscrew the back cover and run cable per photo below. Once the cable is connected, screw the back cover on to the PCJ and the installation is complete. In the future, use the side clamps to remove the back cover, disconnect the cable and slide out the pyrometer

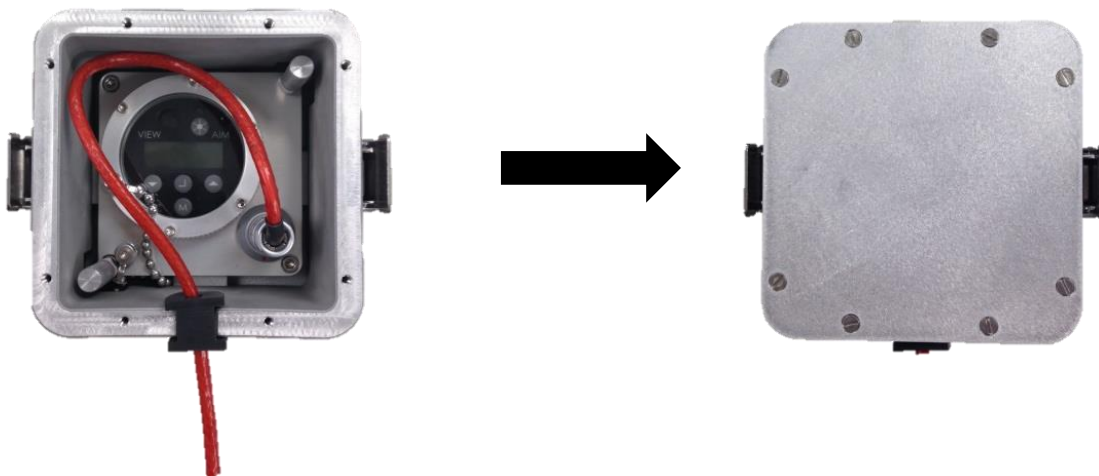



**Side View**

LEGEND: INCHES [MILLIMETERS]

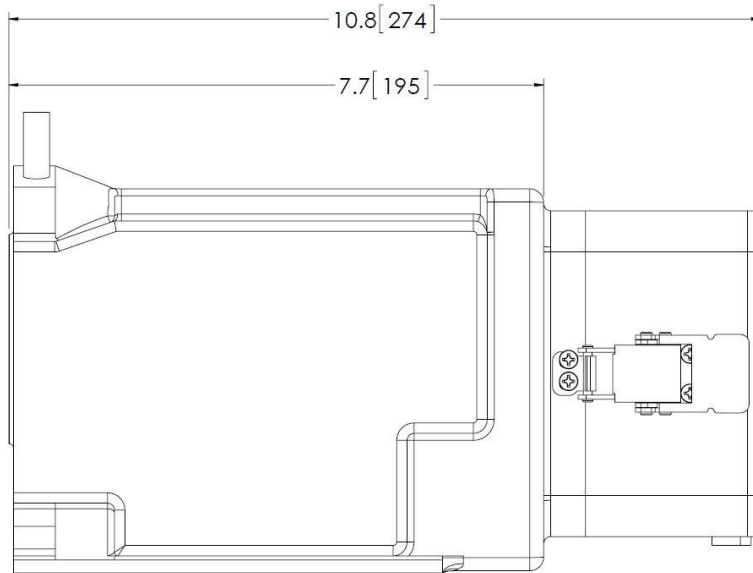

**Bottom View**

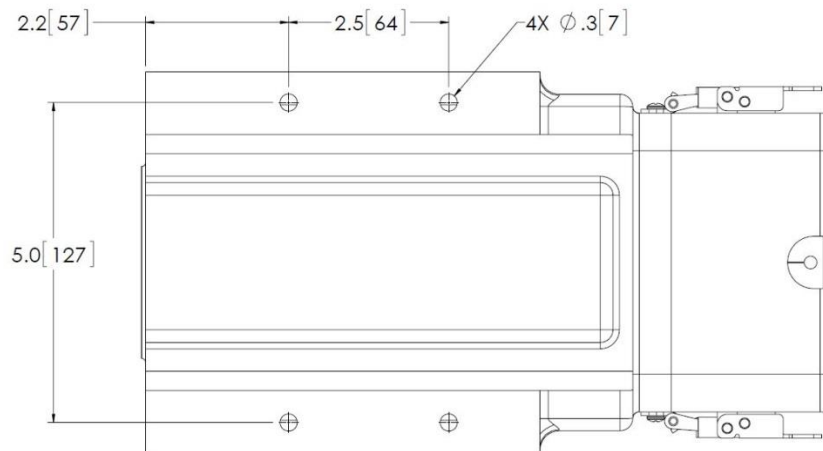

**Front View**

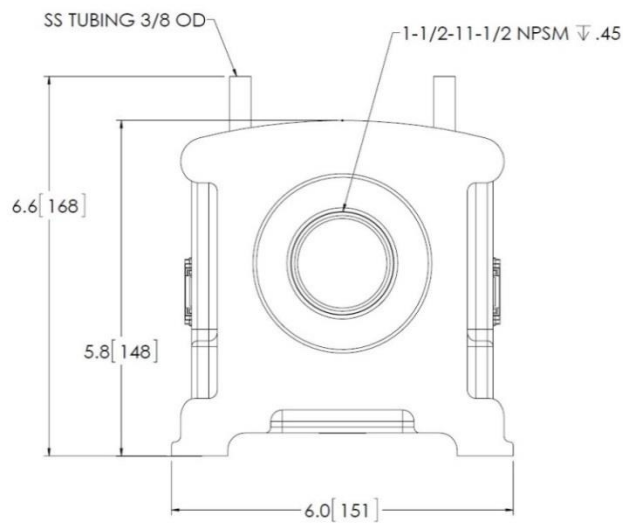

## 2.4 MOUNTING ACCESSORIES

LEGEND: INCHES [MILLIMETERS]

### 2.4.1 Traditional Style Swivel Bracket (SB)

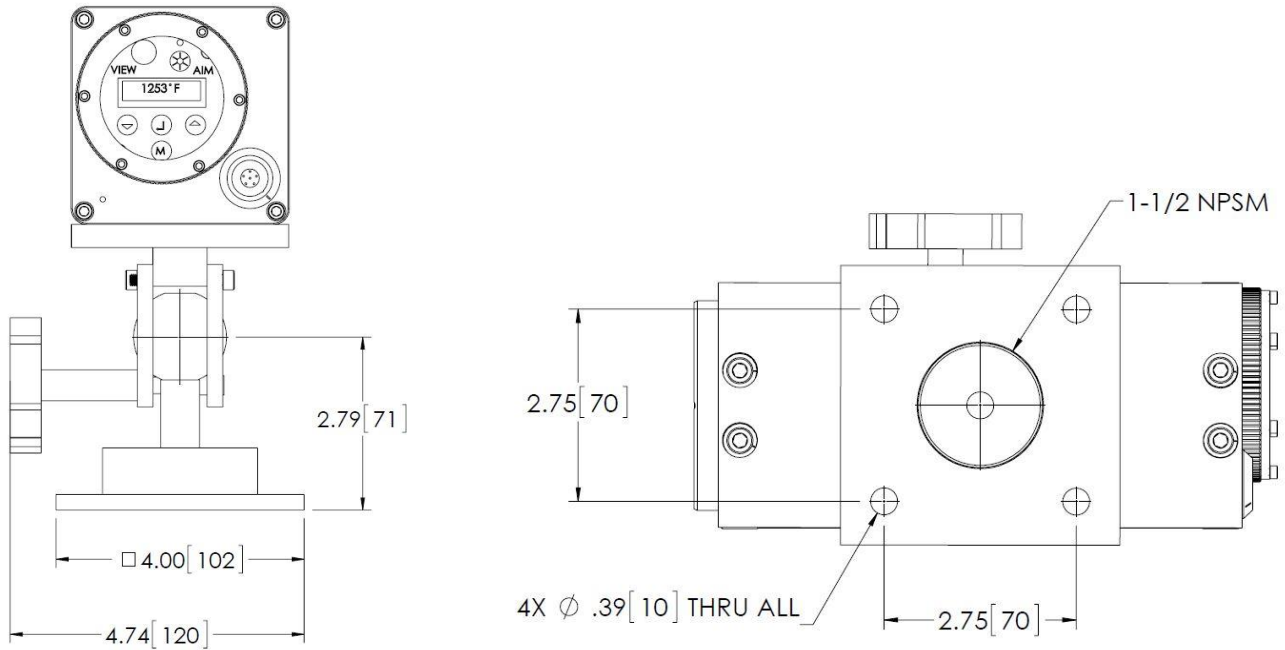

### 2.4.2 Fiber Optic Swivel Bracket (FOSB)

1/4 NPT  
CLEAN, DRY AIR  
3-5 CFM / 5-8m<sup>3</sup>ph

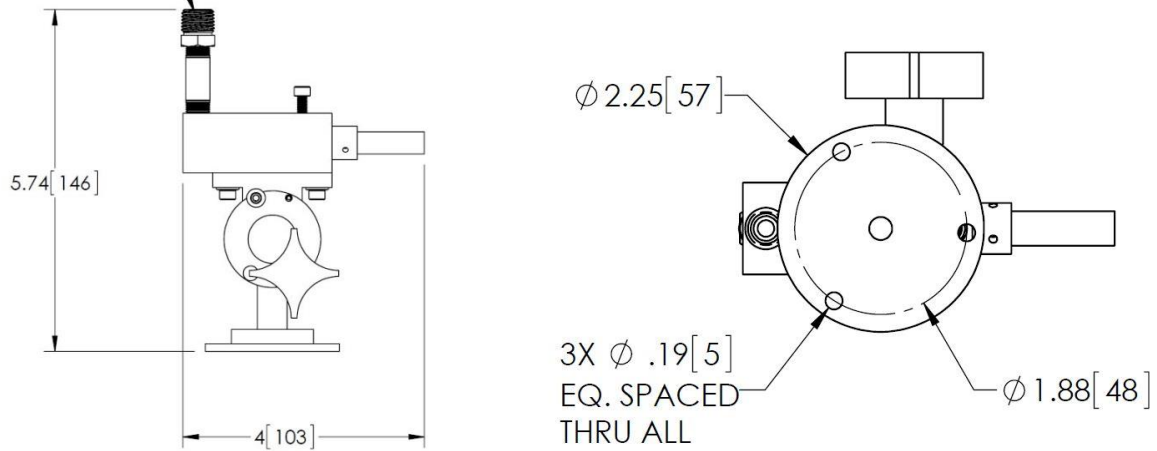

### 2.4.3 Fiber Optic Sight Tube Swivel Bracket (STSB)

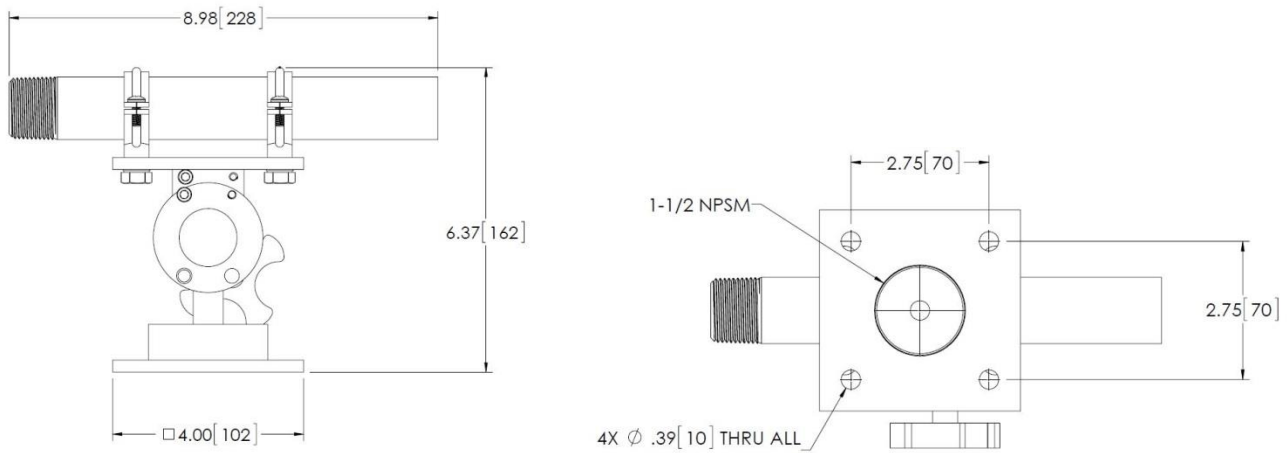

## 2.5 FLANGE MOUNTS FOR TRADITIONAL AND FIBER OPTIC STYLE PYROMETERS

Williamson offers a wide range of flange mount accessories which include an air purge, union disconnect, optional windows and 150lb or 300lb ratings. The most popular configurations are illustrated below.

### Fiber Optic and Traditional Side View

LEGEND: INCHES [MILLIMETERS]

FIBEROPTIC FLANGE MOUNT

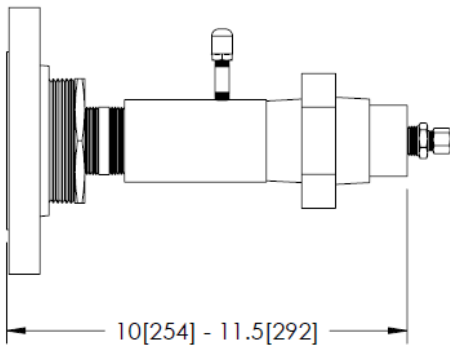

FLANGE MOUNT

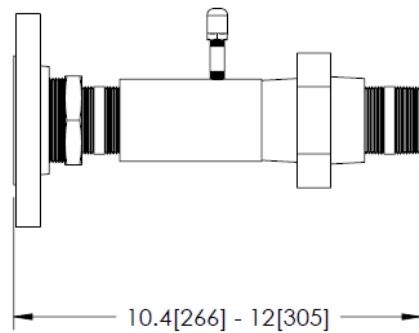

### FM3 and FM2 Flange Face

LEGEND: INCHES [MILLIMETERS]

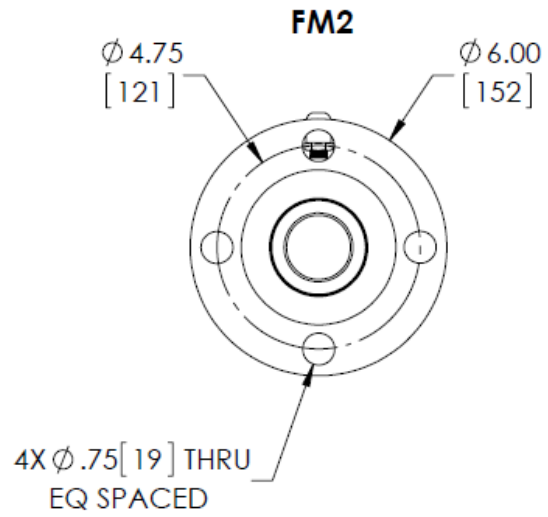
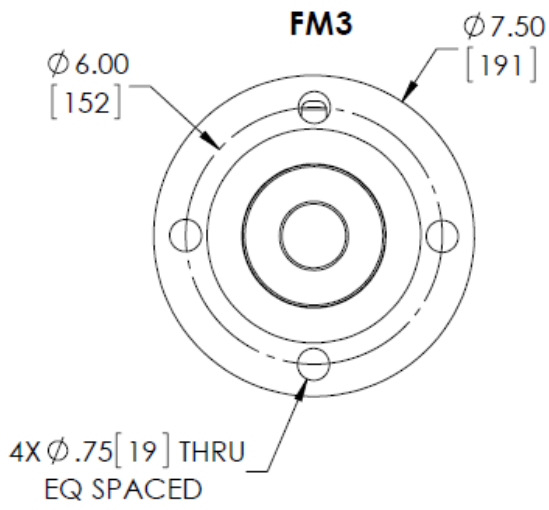

### FM1 and FMP Flange Face

LEGEND: INCHES [MILLIMETERS]

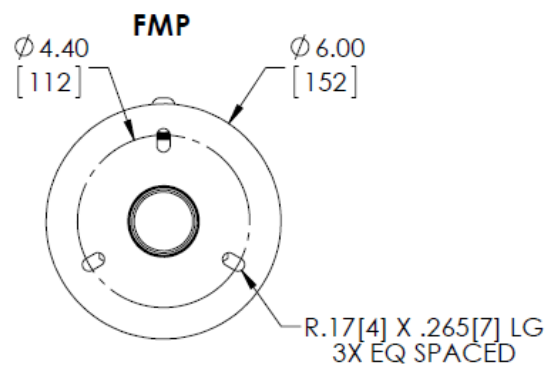
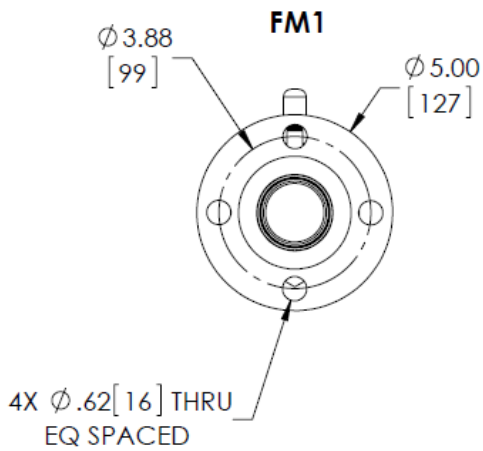

## 2.6 EXPLOSION (EXP) PROOF CONFIGURATION

LEGEND: INCHES [MILLIMETERS]

### Front and Side View

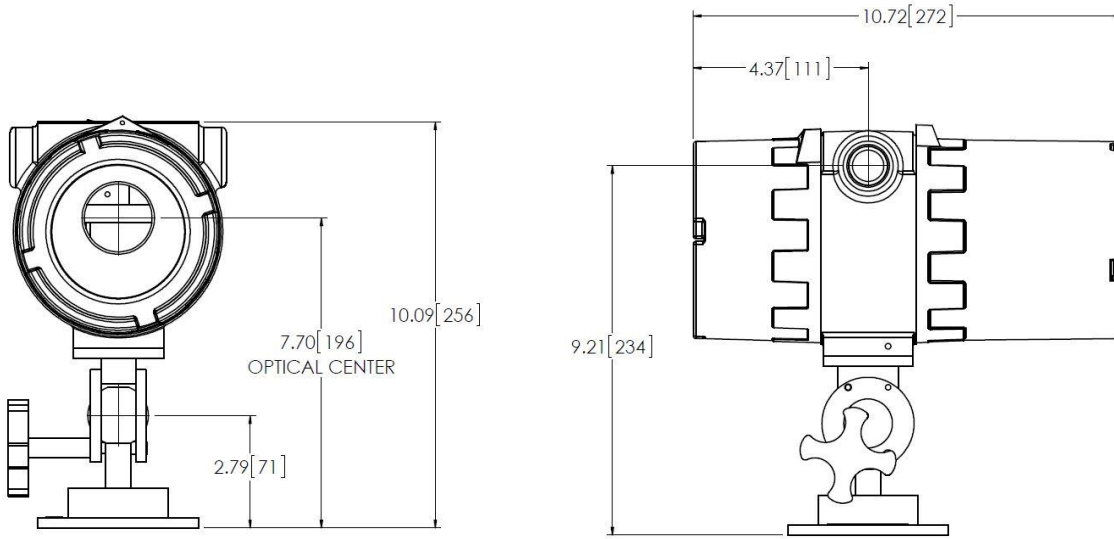

### Rear and Bottom View

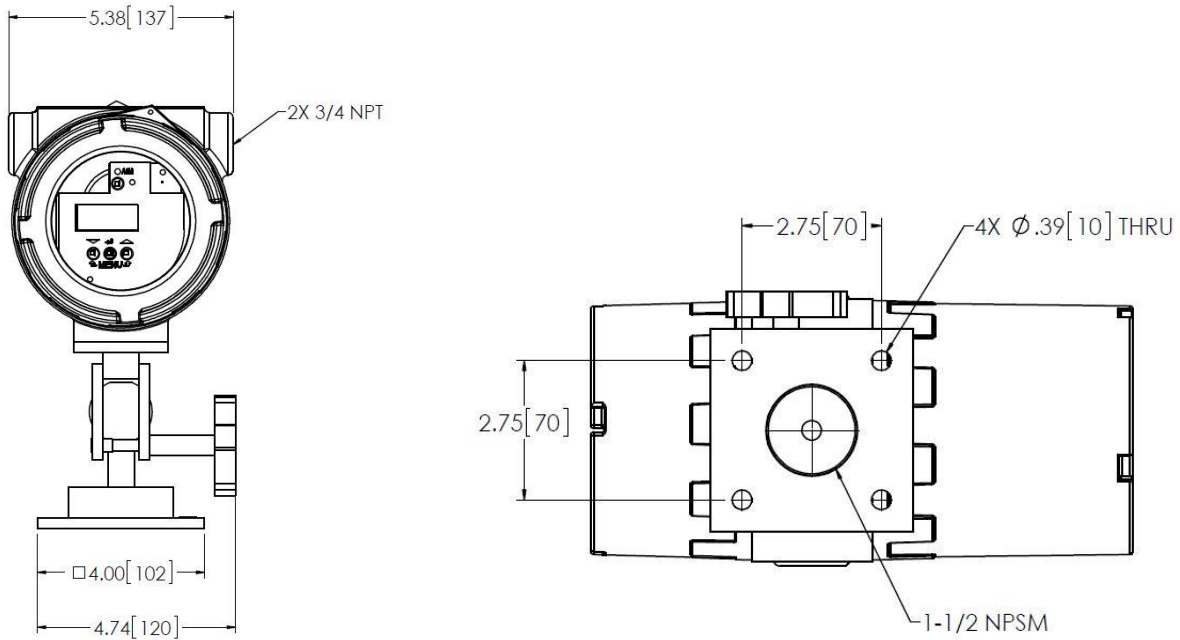

## 2.7 INTERFACE MODULE (IM)

LEGEND: INCHES [MILLIMETERS]

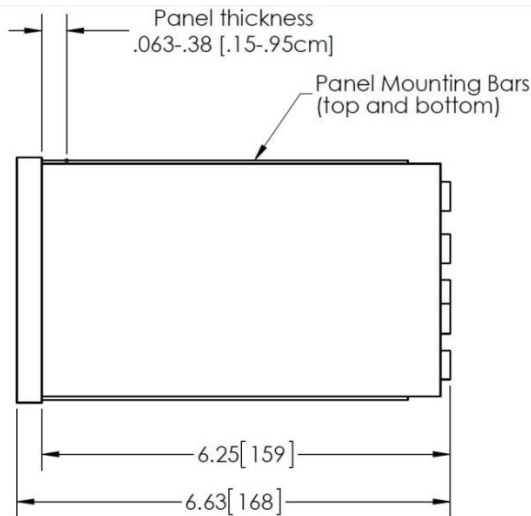
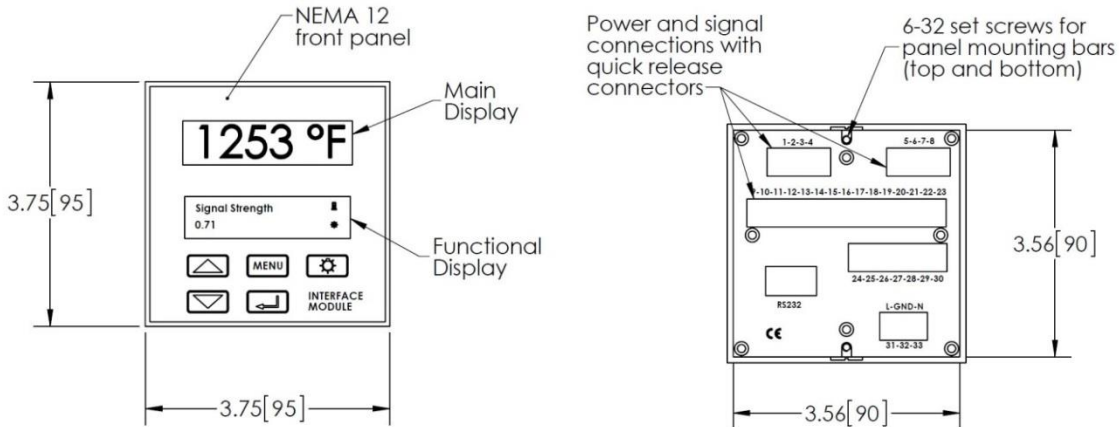

The Interface Module (IM) provides a remote human interface with two displays, two analog output signals, two form-C alarms, one TTL alarm, an analog input signal and digital communications. These human interfaces permit the operator to view measured values, to view pyrometer settings, and to navigate the setup menu. The IM also includes an AC to DC power supply, and it is required for connecting a laptop with ProView software. The two IM displays work as follows:

- Interface Module Main Display:** The Enter key is pressed and held to scroll through select measured parameter values. When the single-wavelength temperature value is displayed on a ratio or multi-wavelength pyrometer, three horizontal lines will alternately appear with the temperature unit symbol (F or C) to avoid confusion with viewing the ratio or multi-wavelength temperature readings.
- Interface Module Functional Display:** The arrow keys are used to scroll through measured parameter values and active pyrometer settings. Press the menu button to access the setup menu, and use the enter button and arrow keys to navigate and edit the pyrometer settings.

### Interface Module Interchangeability

When an Interface Module is used, the analog output parameters and the alarm parameters are stored in the Interface Module (IM). All other parameter values are stored in the pyrometer itself. When interchanging IMs, be sure to confirm that the analog output parameters and the alarm parameters are configured appropriately for your needs.

### 3.0 ELECTRICAL INSTALLATION

#### 3.1 ANALOG AND DIGITAL CONFIGURATIONS

The Pro Series pyrometers can operate in an analog or digital mode. The mode of operation is set at the factory, and it can easily be adjusted in the field using the menu system (no jumpers required).

- In the analog mode, the pyrometer operates as a stand-alone transmitter that provides an analog output and requires 24 V dc power.
- In the digital mode, the pyrometer provides an RS485 output so that it can communicate with the optional Interface Module which requires line power. The digital mode can also be used to communicate with the pyrometer using Willy-Bus Communications or to setup a multi-drop network via an AnyBus Module.

Power Requirements		
	Stand-Alone	With IM
Nominal	24 Vdc, 0.3A	100-240 Vac, 0.125A

A six conductor instrument grade hook up cable is recommended, although some configurations are compatible with four wires. The Williamson standard electrical cable is Beldon 83606 or equal, which is a high temperature, corrosion-resistant, Teflon-sheathed 22 gage six-conductor electrical instrumentation cable with an overall copper braided shield.

Electrical Cable Requirements	
Analog Mode	1000 ohm maximum impedance
Digital Mode	4000ft/ 1225m maximum length

#### 3.2 ELECTRICAL WIRING

Stand Alone Configuration, Pro Series Pyrometers					
Pyrometer Connector Pin	Cable Color	ANALOG MODE For Stand Alone Configuration or analog interface	Internal Ribbon Cable Colors	DIGITAL MODE For Williamson Interface Module (IM) or Stand Alone Digital Mode	IM Connections
1	Red	+24Vdc / 200mA Max	Brown	+24Vdc / 200mA Max	30
2	White	24Vdc Return (circuit common)	Red	24Vdc Return (circuit common)	29
3	Green	Analog Output (0-20mA or 4-20mA)	Orange	RS485 Full Duplex Receive +	26
4	Black	Analog Output Return	Yellow	RS485 Full Duplex Receive -	25
5	Blue	Relay, TTL+, Hold Reset, Input+ or Remote Aim Lt (see jumper settings)	Green	RS485 Full Duplex Transmit +	28
6	Orange	Relay, TTL-, Hold Reset, Input- or Remote Aim Lt (see jumper settings)	Black	RS485 Full Duplex Transmit -	27
Shield	Clear	Earth Ground		Earth Ground (Shield)	Terminate at Pyrometer

### 3.3 JUMPER POSITIONS

Jumper Positions	
<b>Aiming Feature</b>	
[Aim Light or None]	J4 = 5-6
Laser Aiming	J4 = 4-5
External Aim Light Switch	J4 = 2-3 & 8-9 J5 = 11-12
<b>Built-In Alarm or Analog Input</b>	
Analog Input	J4 = 1-2 & 8-9 J5 = 11-12
Built-In Relay NO	J4 = 7-8 & 10-11 J5 = 8-9 & 10-11
[Built-In Relay NC]	J4 = 7-8 & 10-11 J5 = 7-8 & 10-11
RAO Feature (TTL Output)	J4 = 7-8 & 11-12
<b>Digital Communications</b>	
[Single-Drop Mode]	J5 = 1-2 & 4-5
Multi-Drop Mode	Remove Single-Drop Jumpers
<b>Default Settings</b>	
J4 = 1-2, 5-6, 7-8 & 10-11 J5 = 1-2, 4-5, 7-8, & 10-11	

### 3.4 EXPLOSION-PROOF ELECTRICAL WIRING

Pro Series EXP Configuration			
Relay Board Terminal	ANALOG MODE (JUMPER POSITIONS J3=2-3 & J4=2-3) For analog interface	DIGITAL MODE (JUMPER POSITIONS J3=1-2 & J4=1-2) For Williamson Interface Module (IM) or Stand Alone Digital Mode)	
		IM Connections	Function
1	+24Vdc / 300mA Max	30	+24Vdc (300mA)
2	24Vdc Return (Circuit Common)	29	24Vdc Return (Circuit Common)
3	mA Output + (0-20mA or 4-20mA)	26	RS485 Full Duplex Receive +
4	mA Output Return	25	RS485 Full Duplex Receive -
5	Not Used	28	RS485 Full Duplex Transmit +
6	Not Used	27	RS485 Full Duplex Transmit -
7	Relay Common (C)		Not Used
8	Relay Normally Open (N.O.)		Not Used
	Earth Ground (Shield)		Earth Ground (Shield) – terminated at pyrometer housing



### 3.5 INTERFACE MODULE ELECTRICAL HOOK UP CONNECTIONS

ID	FUNCTION	NOTES			
<b>J12</b>	<b>ALARM / RELAY OUTPUT 1</b>	Relay Rating: 4 amps at 250Vac, or 2.5 amps at 30Vdc Relay Activation Time: 15ms max Reset Time: 5ms max Failsafe Operation: Normal = Power Off or Above Setpoint Energized = Power On & Below Setpoint			
1	Normally Closed (N.C.)				
2	Common (C.)				
3	Common (C.)				
4	Normally Open (N.O.)				
<b>J13</b>	<b>ALARM / RELAY OUTPUT 2</b>	See above.			
5	Normally Closed (N.C.)				
6	Common (C.)				
7	Common (C.)				
8	Normally Open (N.O.)				
<b>J6</b>	<b>DISPLAY INPUT, OUTPUT, &amp; ALARM FUNCTIONS (Green Connector)</b>				
9	Analog Input	Input = 4-20mA or 0-20mA. Use shunt resistor for voltage input (0-10 V max).			
10	Circuit Common	Output = 4-20mA or 0-20mA. Use shunt resistor for voltage output (0-10 V max).			
11	Analog Output 2				
12	Circuit Common				
13	Analog Output 1				
14	Circuit Common	Note: all Circuit Commons are common to each other.			
15	TTL Alarm Output	Rating = 2mA at 5Vdc maximum			
16	Circuit Common	Note: all Circuit Commons are common to each other.			
17	Hold Reset	Short to Circuit Common for reset.			
18	Circuit Common	Note: all Circuit Commons are common to each other.			
19	Display Hold or Digital Pulse Output	Short to Circuit Common to initiate desired function. (Output values remain live)			
20	RS485 Full Duplex Receive -	Maximum Distance = 4000 feet			
21	RS485 Full Duplex Receive +				
22	RS485 Full Duplex Transmit -				
23	RS485 Full Duplex Transmit +				
<b>J7</b>	<b>SENSOR CONNECTION (Green Connector)</b>				
	<b>Interface Module</b>	<b>Wire</b>	<b>Sensor</b>		
24	Earth Ground (shield)	Clear	Shield	Capacitively isolated from circuit common	
25	RS485 Full Duplex Receive -	Black	D	Pyrometer Connections. Maximum Length: 4000 feet.	
26	RS485 Full Duplex Receive +	Green	C		
27	RS485 Full Duplex Transmit -	Orange	F		
28	RS485 Full Duplex Transmit +	Blue	E		
29	24Vdc Return (circuit common)	White	B	Pyrometer Power	
30	+24Vdc	Red	A		
<b>IEC</b>	<b>AC Line Cord</b>				
<b>Country</b>	<b>Plug Types</b>	<b>Manufacturer</b>	<b>Ratings</b>	<b>Part Number</b>	<b>Specifications</b>
North America	NEMA5-15P to IEC 320-C13-6ft Wire Size 18 AWG	PHIHONG USA	125V 60° C 10A	AC30UNA	<a href="https://www.phihong.com/admin/uploads/3-Wire_PowerCord-NA.pdf">https://www.phihong.com/admin/uploads/3-Wire_PowerCord-NA.pdf</a>
United Kingdom	BS1363A to IEC 320-C13-2.5m Wire Size 1.0mm	PHIHONG USA	250V 70° C 10A	AC30UUK	<a href="https://www.phihong.com/admin/uploads/3-Wire_PowerCord-UK.pdf">https://www.phihong.com/admin/uploads/3-Wire_PowerCord-UK.pdf</a>
Continental Europe	CEE 7VII to IEC 320-C13- 6ft Wire Size 0.75mm	PHIHONG USA	250V 70° C 10A	AC30UEU	<a href="https://www.phihong.com/admin/uploads/3-Wire_PowerCord-EU.pdf">https://www.phihong.com/admin/uploads/3-Wire_PowerCord-EU.pdf</a>
Japan	JIS 8303 to IEC 320 C13 – 6ft Wire Size 1.25mm	QUALTEK	125V 60° C 12A	397003-01	<a href="http://www.qualtekusa.com/images/Power%20Cords/PDF%20Files/39700301.pdf">http://www.qualtekusa.com/images/Power%20Cords/PDF%20Files/39700301.pdf</a>
<b>J9</b>	<b>RS232 CONNECTION (DB9 Connector)</b>				
DB9	(1) N.C.				

(2) PC RS232 TX	RS232 Connections (USB Connections pending)
(3) PC RS232 RX	
(4) N.C.	
(5) Circuit Common	
(6) N.C.	
(7) PC RS232 CTS	
(8) PC RS232 RTS	
(9) N.C.	

### 3.6 ALARM FUNCTION WIRING

Stand-Alone Alarm Status							
Jumper Configuration	Alarm Logic	Diagnostic Test Mode			Loss of Power	Below Setpoint	Above Setpoint
		Disabled	On	Off			
Mechanical Relay N.O. Setting	Normal	Open	Closed	Open	Open	Closed	Open
	Reverse	Open	Closed	Open	Open	Open	Closed
Mechanical Relay N.C. Setting	Normal	Closed	Open	Closed	Closed	Open	Closed
	Reverse	Closed	Open	Closed	Closed	Closed	Open
TTL Alarm	Normal	0 volts	5 volts	0 volts	0 volts	5 volts	0 volts
	Reverse	0 volts	5 volts	0 volts	0 volts	0 volts	5 volts

RAO Alarm Status						
Alarm Logic	Diagnostic Test Mode			Loss of Power	Below Setpoint	Above Setpoint
	Disabled	On	Off			
Normal	Open	Closed	Open	Open	Closed	Open
Reverse	Open	Closed	Open	Open	Open	Closed

Dual Alarm RAO Alarm Status							
Alarm Logic	Jumper Position: J4 (Alarm 1) & J5 (Alarm 2)	Diagnostic Test Mode			Alarm1 = Pins 6&7, Alarm2 = Pins 6&8		
		Disabled	On	Off	Loss of Power	Below Setpoint	Above Setpoint
Normal	Shorting Pins 2&3 [Default]	Closed	Open	Closed	Closed	Open	Closed
	Shorting Pins 1&2	Open	Closed	Open	Open	Closed	Open
Reverse	Shorting Pins 2&3	Open	Closed	Open	Open	Closed	Open
	Shorting Pins 1&2	Closed	Open	Closed	Closed	Open	Closed

Interface Module Alarm Status							
Alarm Terminal Positions		Diagnostic Test Mode			Loss of Power	Below Setpoint	Above Setpoint
		Disabled	On	Off			
Mechanical Relays	Normally Closed Position (Alarm 1 Pins 1&2, Alarm 2 Pins 5&6)	Closed	Open	Closed	Closed	Open	Closed
	Normally Open Position (Alarm 1 Pins 3&4, Alarm 2 Pins 7&8)	Open	Closed	Open	Open	Closed	Open
TTL Alarm	Normal	0 volts	5 volts	0 volts	0 volts	5 volts	0 volts
	Reverse	0 volts	5 volts	0 volts	0 volts	0 volts	5 volts

## 4.0 NAVIGATING THE PYROMETER MENU

### 4.1 DISPLAY MODE

In the display mode, parameter values may be viewed but not changed.

#### Measured Parameters

Measured Parameter	Analog Output	Digital Output	Alarm Output	Description
Filtered Temperature	Yes	Yes	Yes	The measured temperature value after signal conditioning is applied. Note: ESP Filtering does not act upon the digital FT value.
Unfiltered Temperature	Yes	Yes	Yes	The measured temperature value before any signal conditioning is applied.
Signal Strength (Emissivity)*	Yes	Yes	Yes	The apparent emissivity value. *Models TC, DW, MW
Signal Dilution (IR Energy)*	Yes	Yes	Yes	A measure of infrared energy *Models TC, DW, MW
Single-Wavelength Temperature*	Yes	Yes	Yes	The single-wavelength measured temperature value after signal conditioning is applied. *Models TC, DW, MW
Rate of Change	Yes	Yes	Yes	ROC = Change in Temperature X ROC Multiplier. Used for hot spot detection. Based on the rate of rise in temperature
Ambient Temp	Yes	Yes	Yes	The temperature inside the pyrometer housing
Peak Ambient Temperature	No	Yes	No	The maximum running ambient temperature value
Cell Strength*	No	Yes	No	An indicator of detector health. $0.7 < \text{Good} < 1.2$ *Auto-Null Models (SW-2A, SW-29 and SP-PF) only
Motor Current*	No	Yes	No	A reading greater than 12 mA or a highly erratic reading indicates poor motor health. * SW-2A, SW-29 and SP-PF, DW, MW
Out of Range	No	Yes	Yes	Indicates that the current reading is outside of the specified temperature range of the pyrometer.
ESP Status*	No	Yes	Yes	Indicates that the current temperature reading is being suppressed because the Signal Strength or Signal Dilution values are outside of the specified limits. *Models = TC, DW, MW
External Emissivity	No	Yes	No	Analog Input value for Emissivity parameter setting
External Temp	No	Yes	No	Analog Input value for Alarm Setpoint Temperature

### 4.2 SET UP MODE – MAIN MENU

When in the operating display mode, a filling thermometer icon is present. When in the set up mode, the filling thermometer icon disappears.

- Press the Menu button to enter the set up mode at the Main Menu level.
- Use the Arrow keys to scroll between submenu groups.
- Use the Enter button to enter a submenu group.
- Use the Menu button to exit the set up mode.

Submenu Groups: Main Menu Level						
Signal Conditioning	Configure I/O	Configure Alarms	Configure ESP	Diagnostics	System Specifications	Configure Network

### 4.3 SET UP MODE, SUBMENU LEVEL

- Press Enter to enter a Submenu group from the Main Menu level.
- Use the arrow keys to scroll between parameters and to change parameter values.
- Use the Enter button to unlock a parameter value and to lock in a new parameter value.
- Use the Menu button to exit a parameter without changing the value, and to return to the Main Menu level.

### 4.3.1 Signal Conditioning Submenu Group

Parameter (options)	Values [Default Value]	Description
<b>Average Time</b>	Disabled – 240.0 sec <b>[2.0]</b>	Applied to the Filtered Temperature Value
<b>Temperature Reset</b>	<b>[Ramp],</b> Snap, Resume	During the time average period after the pyrometer reading first enters the range of measurement, the Filtered Temperature value: Ramps from the Spec Bot Temp Snaps to the instantaneous Unfiltered Temperature value Resumes from the previous Filtered Temperature value saved from before the pyrometer reading went out of range
<b>Temperature Hold</b> • <b>[Disabled]</b>		Holds the Peak or Valley Temperature Value
• Peak Hold – Time Reset	<b>[Disabled]</b> to 360 seconds	The peak temperature is held for the peak hold time.
• Peak Hold – Decay Rate	1 to <b>[300°F]</b> /second	The peak temperature falls at the specified rate
• Peak Hold – Temp Reset	Range of pyrometer	The held temperature value is reset when the unfiltered temperature value rises through the specified temperature
• Valley Hold – Time Reset	<b>[Disabled]</b> to 360 seconds	The low temperature is held for the valley hold time.
• Valley Hold – Decay Rate	1 to <b>[300°F]</b> /second	The low temperature rises at the specified rate
• Valley Hold – Temp Reset	Range of pyrometer	The held temperature value is reset when the unfiltered temperature value falls through the specified temperature
Note: Interface Module Pin 17 resets the held temperature value when shorted to ground		
<b>Temperature Scale</b>	Fahrenheit or Celsius	Affects displayed value only
<b>E-Slope Offset*</b>	-1.000 to +1.000, <b>[0.000]</b>	Adjusts pyrometer temperature reading. E-Slope Offset from an E-Slope value of 1.000 *Models = TC, DW, MW
<b>Emissivity*</b>	0.010 to 1.500 <b>[1.000]</b>	Adjusts pyrometer temperature reading *Models = SW, LW, SP
<b>Rate of Change Multiplier</b>	0 to <b>[100]</b>	ROC = change in Temperature X ROC Multiplier. Adjusts sensitivity for hot spot detection feature
<b>Bottom Hold</b>	<b>[2.0]</b> 0 to 24 seconds	Prevents premature turn-on below range. Auto Null models.
<b>Reset Group Default Values</b>		Sets Signal Conditioning parameters to Default values.
<b>Return to Main Menu</b>		Navigates to the Main Menu level of the set up mode
<b>Return to Display Mode</b>		Navigates out of set up mode

### 4.3.2 Configure I/O Submenu Group

Parameter (options)	Values [Default Value]	Description
<b>Sensor Output</b>	Digital, Analog	Use Digital Mode for use with IM Interface Module
<b>Output 1 Parameter</b>		
• Filtered Temperature		
• Unfiltered Temperature		
• Single WL Temperature		
• Ambient Temperature	32-200°F or 0-93.3°C	This output range is fixed
• Cell Strength*	0.00-2.00 (0.9-1.1 = good)	A measure of detector health *(Auto Null Models)
• Signal Strength (Emissivity)* Sig Strength Scale	[0-2000], 0-1500, 0-1000, 0-500	2000 = 2.000, 1000 = 1.000, 1500 = 1.500, 500 = 0.500 *Models TC, DW, MW
• Signal Dilution (IR Energy)*	0-1600	This output range is fixed. *Models TC, DW, MW
• ROC (Rate of Change)	0-1000	This output range is fixed. Used for hot spot detection
<b>Output 1 Scale</b>	4-20 mA, 0-20 mA	A shunt resistor can convert to voltage output
<b>Output 1 Range*</b>		*Only available when Output 1 is set to Filtered Temp, Unfiltered Temp, or Single WL Temp
• Spec Range	Range of pyrometer	
• Custom Range 0/4 mA Temp (O1) 20 mA Temp (O1)	Inside of Spec Range Inside of Spec Range	The 0/4 mA value must be at least 1 degree lower than the 20 mA value
<b>Output 2 Parameter</b>		
• Filtered Temperature		
• Unfiltered Temperature		
• Single WL Temperature		
• Ambient Temperature	32-200°F or 0-93.3°C	This output range is fixed
• Cell Strength*	0.00-2.00 (0.9-1.1 = good)	A measure of detector health *(Auto Null Models)
• Signal Strength (Emissivity) Sig Strength Scale*	[0-2000], 0-1500, 0-1000, 0-500	2000 = 2.000, 1000 = 1.000, 1500 = 1.500, 500 = 0.500 *Models TC, DW, MW
• Signal Dilution (IR Energy)*	0-1600	This output range is fixed. *Models TC, DW, MW
• ROC (Rate of Change)	0-1000	This output range is fixed. Used for hot spot detection
<b>Output 2 Scale</b>	0-20 mA, 4-20 mA	A shunt resistor can convert to voltage output
<b>Output 2 Range*</b>		*Only available when Output 2 is set to Filtered Temp, Unfiltered Temp, or Single WL Temp
• Spec Range	Range of pyrometer	
• Custom Range 0/4 mA Temp (O2) 20 mA Temp (O2)	Inside of Spec Range Inside of Spec Range	The 0/4 mA value must be at least 1 degree lower than the 20 mA value
<b>Pin 19 Input</b> (Actions occur when pin 19 is shorted to ground)	[Display Hold], Transmit Temp, Transmit All	Freezes the displayed value Digitally transmits the Filtered Temperature Value Digitally transmits a string of measured parameters
<b>Input Parameter</b>		
• [Disabled]		
• E-Slope Offset, Input Scale	-0.200 to + 0.200 [4-20 mA], 0-20 mA	Positive offset will raise the reading / Negative offset will lower the reading
• Emissivity Emissivity Range Input Scale	[0-1500], 0-1000, 0-500 [4-20 mA], 0-20 mA	Higher / Lower value Decreases / Increases Reading 1500 = 1.500, 1000 = 1.000, 500 = 0.500
• Alarm 1 Temp Input Scale	Range of pyrometer [4-20 mA], 0-20 mA	Adjusts the temperature alarm setpoint value
<b>Reset Group Default Values</b>		Sets I/O parameters to Default values.
<b>Return to Main Menu</b>		Navigates to the Main Menu level of the set up mode
<b>Return to Display Mode</b>		Navigates out of set up mode

### 4.3.3 Configure Alarms Submenu Group

Parameter (options)	Values [Default Value]	Description
<b>Alarm 1 Parameter</b> [Disabled]		
• Filtered Temperature Alarm 1 Temperature	Range of pyrometer	Alarms when Filtered Temperature is above the selected value
• Out of Range		Alarms when the pyrometer reading is out of the range
• Ambient Warning Alarm 1 Ambient	32-200°F or 0-93.3°C	Alarms when the ambient temperature is above selected value
• Signal Dilution* Alarm 1 Sig Dilution	1 to 9000	Alarms when the measured SD is above the selected value *Models TC, DW, MW
• Signal Strength* Alarm 1 Sig Strength	0.000 to 2.000	Alarms when the measured SS is above the selected value *Models TC, DW, MW
• Cell Strength*	0.0 to 2.0	A measure of detector health 0.9-1.1 = good *(Auto Null Models)
• ESP Status*		Alarms when the measured SS or SD values are out of bounds *Models TC, DW, MW
• Rate of Change Alarm 1 ROC	[0] - 1000	Alarms when the measured ROC value is above selected value
<b>Alarm 2 Parameter</b> [Disabled]		
• Filtered Temperature Alarm 2 Temperature	Range of pyrometer	Alarms when Filtered Temperature is above the selected value
• Out of Range		Alarms when the pyrometer reading is out of the range
• Ambient Warning Alarm 2 Ambient	32-200°F or 0-93.3°C	Alarms when the ambient temperature is above selected value
• Signal Dilution* Alarm 2 Sig Dilution	1 to 9000	Alarms when the measured SD is above the selected value *Models TC, DW, MW
• Signal Strength* Alarm 2 Sig Strength	0.000 to 2.000	Alarms when the measured SS is above the selected value *Models TC, DW, MW
• Cell Strength*	0.0 to 2.0	A measure of detector health 0.9-1.1 = good *(Auto Null Models)
• ESP Status		Alarms when the measured SS or SD values are out of bounds
• Rate of Change Alarm 2 ROC	[0] - 1000	Alarms when the measured ROC value is above selected value
<b>TTL Alarm Parameter</b> [Disabled]		See Alarm Functions Table for detailed description of alarm operation
• Filtered Temperature TTL Alarm Temperature	Range of pyrometer	Alarms when Filtered Temperature is above the selected value
• Out of Range		Alarms when the pyrometer reading is out of the range
• Ambient Warning TTL Alarm Ambient	32-200°F or 0-93.3°C	Alarms when the ambient temperature is above selected value
• Signal Dilution* TTL Alarm Sig Dilution	1 to 9000	Alarms when the measured SD is above the selected value *Models TC, DW, MW
• Signal Strength* TTL Alarm Sig Strength	0.000 to 2.000	Alarms when the measured SS is above the selected value *Models TC, DW, MW
• ESP Status		Alarms when the measured SS or SD values are out of bounds
• Cell Strength*	0.0-2.0	A measure of detector health 0.9 – 1.1 = good *(Auto Null Models)
• Rate of Change TTL Alarm ROC	[0] – 100	Alarms when the measured ROC value is above selected value
<b>Reset Group Default Values</b>		Sets Alarm parameters to Default values.
<b>Return to Main Menu</b>		Navigates to the Main Menu level of the set up mode
<b>Return to Display Mode</b>		Navigates out of set up mode

#### 4.3.4 Configure ESP Submenu Group\* Only for Models TC, DW, MW

Parameter (options)	Values [Default Value]	Description
Application Algorithm	Algorithms 1–8, Dual / Ratio	Select one of eight ESP Algorithms (MW only)
ESP Sample & Hold	[Disabled], Enabled, Diagnostic	Enabled holds filtered temperature at last valid value while SS or SD values are out of bounds. Diagnostic mode also indicates on the display the filter parameter causing the hold
Signal Strength Filter Lo Sig Strength Hi Sig Strength	[Disabled], Enabled 0.000 – 2.000 0.000 – 2.000	When enabled, the pyrometer will calculate a temperature value only when the measured signal strength (emissivity) value is within the specified range.
Signal Dilution Filter Lo Sig Dilution Hi Sig Dilution	[Disabled], Enabled 1-9000 1-9000	When enabled, the pyrometer will calculate a temperature value only when the measured signal dilution (infrared energy) value is within the specified range.
Sig Strength Avg Time	0.1 – 24.0 seconds [1.0]	Applied to measured signal strength (emissivity) value
Sig Dilution Avg Time	0.1 – 24.0 seconds [1.0]	Applied to measured signal dilution (infrared energy) value
Single Wavelength Emissivity	[Disabled], Enabled 0.000-1.500	Enables a simultaneous calculation of a single-wavelength temperature value using the specified emissivity value
Reset Group Default Values		Sets ESP parameters to Default values.
Return to Main Menu		Navigates to the Main Menu level of the set up mode
Return to Display Mode		Navigates out of set up mode

#### 4.3.5 Diagnostics Submenu Group

Parameter (options)	Values [Default Value]	Description
Aim Shut Off	[Disabled] to 60 minutes	Automatic shut off delay. Disabled = does not automatically turn off
Output 1 Test	[Disabled], 4 mA, 12 mA, 20 mA	Tests the operation of Output 1. Typically used to confirm set up of data acquisition device.
Output 2 Test	[Disabled], 4 mA, 12 mA, 20 mA	Tests the operation of Output 2. Typically used to confirm set up of data acquisition device.
TTL Test	[Disabled], TTL On, TTL Off	Tests the operation of the TTL alarm
Alarm 1 Test	[Disabled], Alarm 1 On, Alarm 1 Off	Tests the operation of Alarm 1
Alarm 2 Test	[Disabled], Alarm 2 On, Alarm 2 Off	Tests the operation of Alarm 2
Menu Access	[Immediate], Delayed	Serves as a lock out feature. Hold Menu button 5 seconds to unlock.
Return to Main Menu		Navigates to the Main Menu level of the set up mode
Return to Display Mode		Navigates out of set up mode

### 4.3.6 System Specification Submenu Group

<b>Parameter</b>	<b>Description</b> – <i>Items in this submenu group may be changed using ProCal software only.</i>
Customer ID	Identifier Field
Sensor Type	Indicates the pyrometer technology
Model Number	Indicates an abbreviated pyrometer part number
Sensor Serial Number	Indicates the specific unit serial number
Specified Bottom Temperature	Indicates the lowest temperature value within the range of the pyrometer
Specified Top Temperature	Indicates the highest temperature value within the range of the pyrometer
Field of View	Indicates the viewing diameter at the focal distance
Manufacture Date	Indicates the date of manufacture.
Last Calibration Date	Indicates the date of most recent factory calibration
Next Calibration Date	Typically set to 2 years after the Last Calibration Date
Warranty Expiration Date	Indicates the warranty expiration date
Sensor Firmware	Indicates the pyrometer firmware revision
Module Firmware	Indicates the firmware revision for the Interface Module, when applicable
Module Serial Number	Indicates the serial number of the Interface Module, when applicable
Return to Main Menu	Navigates to the Main Menu level of the set up mode
Return to Display Mode	Navigates out of set up mode

### 4.3.7 Configure Network Submenu Group

<b>Parameter</b>	<b>Values [Default Value]</b>	<b>Description</b>
Host Baud Rate	[38400], 9600, 19200	Communication with the IM requires a 38400 baud rate
Host Protocol	[Standard], Fieldbus	Communication with the IM requires Standard Protocol
Host Address	[Disabled], 1-255	Assign a Host Address when using Multi-Drop Communication
Host Serial	[RS232], RS485	When an IM is used, the selected serial communication is send-receive and the other is always streaming.
Host RS485	[Full Duplex], Half Duplex	Communication with the IM requires Full Duplex communication
Reset Group Default Values		Sets Configure Network parameters to Default values.
Return to Main Menu		Navigates to the Main Menu level of the set up mode
Return to Display Mode		Navigates out of set up mode



## 5.0 TROUBLESHOOTING

### 5.1 COMMON TROUBLESHOOTING ERRORS

Symptom	Likely Cause and Recommended Action
Pyrometer reads correctly, but Interface Module continuously reads “Initializing, Please Wait”	<ul style="list-style-type: none"> <li>In Configure I/O submenu group, change Output from Analog to Digital.</li> <li>Check cable, connector and power supply integrity.</li> </ul>
Pyrometer reads correctly, but data acquisition device reads the wrong value.	<ul style="list-style-type: none"> <li>In Configure I/O submenu group, confirm Output parameter is the desired setting.</li> <li>Confirm wiring to the correct output (O1 vs O2)</li> <li>Use the Diagnostics submenu group to force Output 1 and / or Output 2 to 4, 12, and 20mA to confirm scaling of data acquisition device.</li> </ul>
Pyrometer reading intermittently drops out.	<ul style="list-style-type: none"> <li>Check cable and connector integrity.</li> <li>Route cable away from high EMI generators such as solenoids and high-power relays.</li> <li>Power the pyrometer using a larger 24 V dc power supply or surge suppressor to protect against power surges.</li> </ul>
Pyrometer and Interface Module both continuously read “Initializing, Please Wait”.	<p>The pyrometer has not communicated with the Interface Module since power was last applied. This is usually an indication of a power fault. [Note: This message will also appear if the pyrometer power is cycled as a result of a “Synchronizing” error message.]</p> <ul style="list-style-type: none"> <li>Check cable, connector and power supply integrity.</li> <li>Swap components (pyrometer, interface module and cable) until the faulty component can be identified.</li> </ul>
Pyrometer and Interface Module both continuously read “Synchronizing”.	<p>The pyrometer has lost communication with the Interface Module, but the Interface Module has not lost power. This is usually an indication of a cable fault.</p> <ul style="list-style-type: none"> <li>Check cable, connector and power supply integrity.</li> <li>Swap components (pyrometer, interface module and cable) until the faulty component can be identified.</li> </ul>

### 5.2 TECHNICAL NOTES

#### Diagnostics Feature

The Williamson pyrometer includes a Diagnostic submenu group in the set up menu. This should be used to confirm the proper scaling of any data acquisition device and that the system wiring is correct. Pyrometer or Interface Module analog output signals and alarm functions may be tested.

#### Entering the Factory Options Submenu Group

Additional adjustments or troubleshooting may require changes in the Factory Options Submenu. Please contact Williamson or your local Williamson representative for instructions on how to access and navigate the Factory Options Submenu.

#### Specified Temperature Span

The Spec Bot Temp and Spec Top Temp parameter values, found in the hidden Factory Options submenu group, may be adjusted to expand the pyrometer range of measurement. The range must be at least 1 degree narrower than the Cal Bot Temp and Cal Top Temp parameter values.

#### Field Calibration

The Pro Series pyrometers include a field calibration feature in the hidden Factory Options submenu group which may be accessed using the human interface (see Factory Options Submenu Group) or using ProView software. For more advanced calibration features (adjusting a single point, reconfiguring a pyrometer), ProCal Software is available.

### 5.3 MAINTENANCE

Remove power to the equipment.

Interface Module. Remove AC power cord from rear of the unit.

Pyrometer: Remove LEMO connector on rear of unit.

Cleaning:



**CAUTION: Do not use MEK, xylene toluene or acetone-based cleaning solvents. These solvents can damage the product labels and keypad graphics.**

**Interface Module:**

Wipe enclosure with damp cloth.



**Pyrometer:**

Wipe enclosure with a damp cloth making sure that the rear hatch cover is closed. Alcohol can be used to clean the rear hatch cover window.